

USER'S GUIDE

Installation & Operation
Instructions

Doppler Flow Meter
Model DFM-IV
Manual Series A.6

Note: This page has been left blank intentionally.

INDEX

Bench Test	4
Connections	4
Keypad System	5
Calibration Menu	6
Totalizer	7
Signal Strength	7
Relay Status Display	8
Password	8
Units /Mode	8
Calibration	9
4-20mA Current Loop	9
Damping	9
Relay Parameters	10
Special Functions	11
Reset Totalizer	11
Sensor Mounting	12
Enclosure Installation	16
Synchronization	17
Backflow Rejection	18
Error/Warning Messages	18
Fuse Replacement	19
Troubleshooting	20
Common Questions and Answers	23
Applications Hotline	25
Product Return Procedure	26
Flow Meter Data Sheet	27
Warranty	28
Appendix A – Options	29
Data Logger	35
RS232C Serial Output	40
Specifications	42
Appendix B - Conversion Table	43
Pipe Charts	44
Calibration Record	47

IMPORTANT NOTE: This instrument is manufactured and calibrated to meet product specifications. Please read this manual carefully before installation and operation. Any unauthorized repairs or modifications may result in a suspension of the warranty.

Available in Adobe Acrobat pdf format

QUICK BENCH TEST:

Connect Sensor as shown below, then Power. Test operation of the DFM-IV by holding the sensor in one hand and rubbing your thumb or fingers briskly across the face (plastic surface) of the sensor. Allow 15 seconds for the DFM-IV to process the signal and display a flow value.

CONNECTIONS:

POWER INPUT: The standard 115VAC model requires AC power input between 100 to 130 VAC 50/60Hz (2 amp fuse is recommended). No adjustments are necessary for voltages within this range. Optional 230VAC requires power input between 200 to 260 VAC 50/60Hz. (See OPTIONS section of this manual for connection of optional 12VDC or 24VDC power input).

IMPORTANT NOTE: To comply with CSA/NRTL electrical safety standards, AC power input and relay connection wires must have conduit entry to the instrument enclosure.

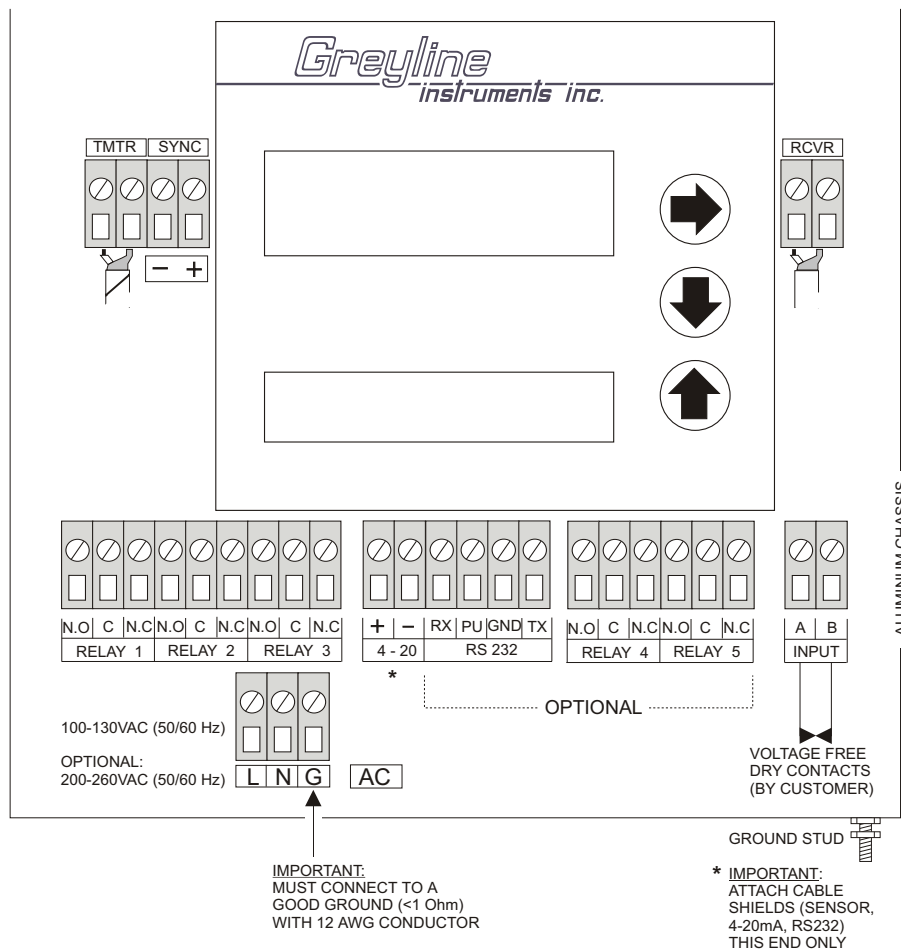

KEYPAD SYSTEM

The DFM-IV has a simple 3-button calibration system. Operating and calibration modes are shown on the 16-digit alphanumeric display. The keypad is used to move around the menu to calibrate the DFM-IV, and to view operating mode and functions. A beep is sounded as each key is pressed. If the keypad is not used for 10 minutes, the DFM-IV will automatically go to RUN mode. Use the keypad to explore the Menu and become familiar with its features.

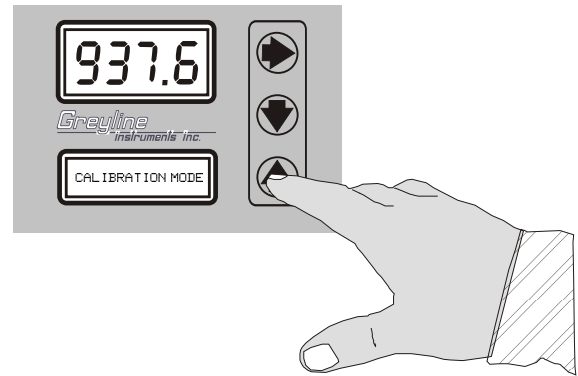

MENU - FLOW CHART

The following diagram shows the DFM-IV Menu system. Arrows show the three directions to leave a box. Pressing a corresponding keypad arrow will move to the next box in the direction shown. Move the cursor (or underline) under numerals and increase or decrease numerals with the \downarrow and \uparrow keys.

At the bottom of each Menu column is a Store? Yes box. To store the calibration values permanently (even through power failure), move the cursor under Yes and press the \downarrow or \uparrow key. If the \downarrow key is pressed with the cursor under Store? no changes will be stored and the system will return to the top of the Menu column.

Calibration Menu

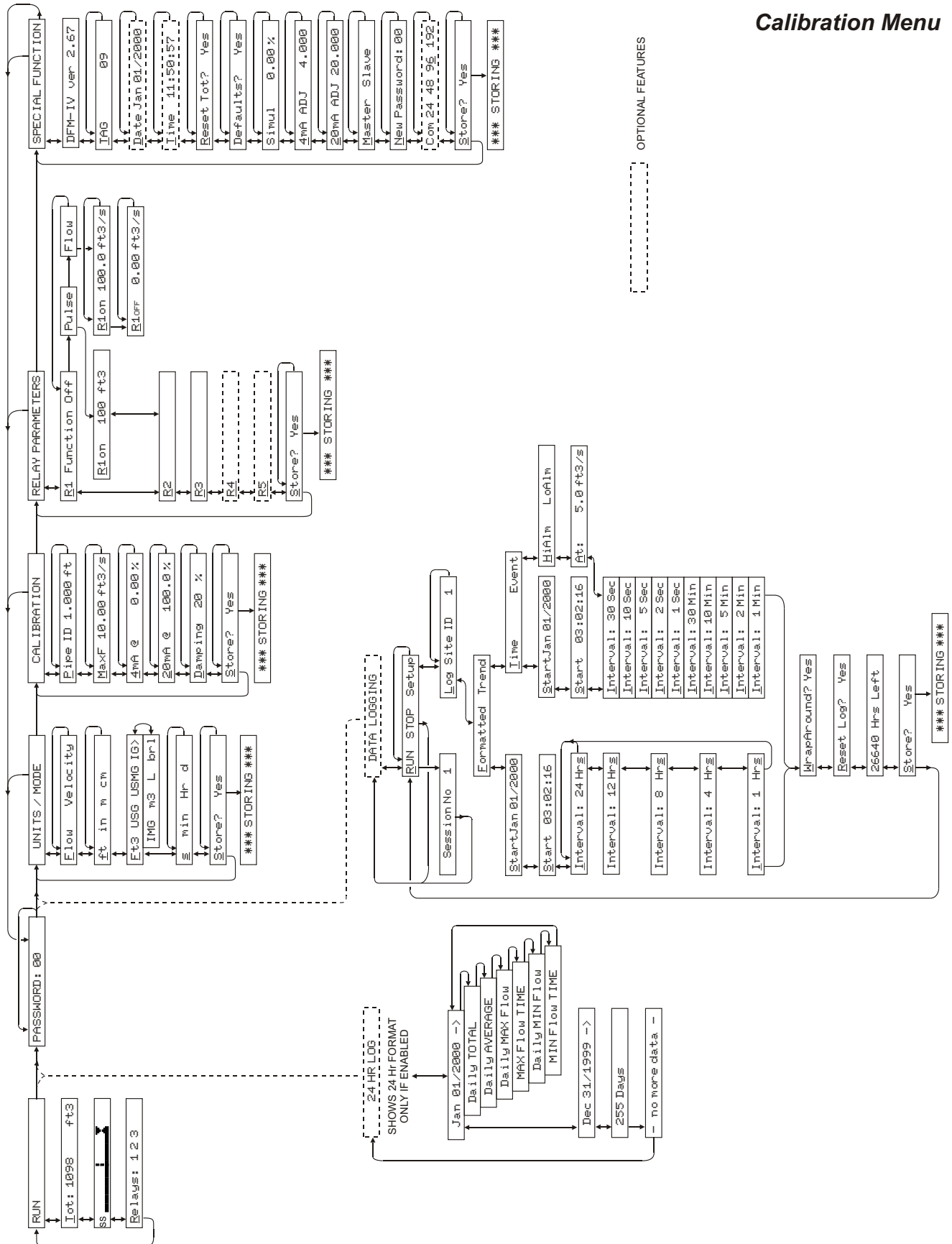

RUN

A scrolling display shows the units selected from the units selection column, the mode of operation (VELOCITY or FLOW), the full scale value for the large numeric display and the TOTALIZER value.

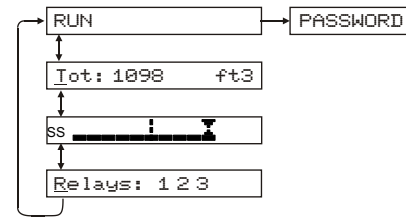

TOTALIZER

From RUN use ↓ key to display the totalizer value. The Totalizer value is updated every 2 seconds with flow volume > 1 litre (0.264 USG). The Totalizer display will show up to 10 digits and then overflows to 0 automatically.

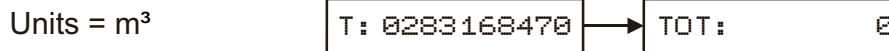
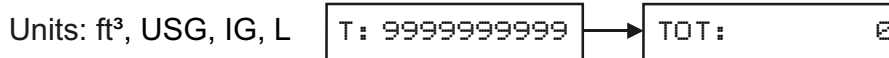

Press ↑ key to return to RUN.

The Totalizer can be reset by going → to SPECIAL FUNCTIONS and ↓ to Reset Tot?.

SIGNAL STRENGTH

<p>From TOTALIZER use ↓ key to get to SS (Signal Strength / Sensitivity).</p>	
<p>Press → to position the cursor under the numeral. Use ↑ or ↓ to increase or decrease signal strength. Minimum setting is '1' Maximum setting is '9'.</p>	
<p>Signal strength should be adjusted so that the 'Signal Strength Arrow' meets the 'Ideal Marker' under normal flow conditions.</p>	
<p>Signal strength must pass the 'Minimum Marker' for the flow meter to display flow.</p>	
<p>It is normal for Signal Strength to fluctuate and rise to full scale under high flow conditions.</p>	

Relays 1 2 3 (Relay Status Display)

Displays state of each Relay. ■ 2 3 4 5 - Reverse character indicates that the Relay is On (energized).

24 HR LOG

DFM-IV Flow Meters with optional Data Logger will display this menu. Refer to OPTIONS section.

PASSWORD

The password (a number from 00 to 99) prevents unauthorized access to the CALIBRATION menu.

From RUN press ➡ to get to PASSWORD.

Press ➡ to place the cursor under the digit and ↓ or ↑ to enter your password. Factory default Password is 00.

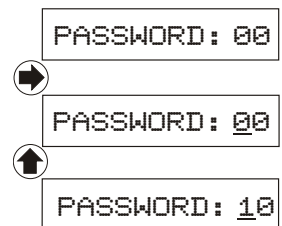

A new password can be stored by going to SPECIAL FUNCTIONS and ↓ to New Password.

UNITS /MODE

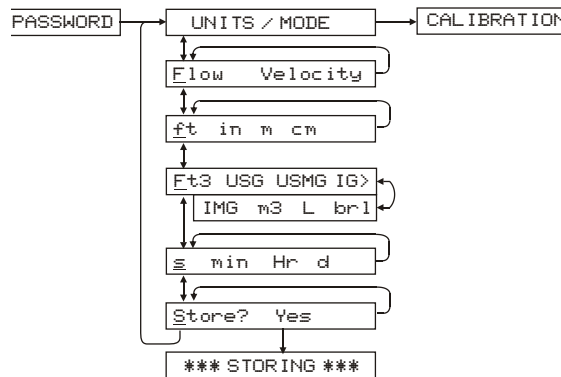

Use ➡ to get to UNITS / MODE, then ↓ to get to Linear Units. Use ➡ to move the cursor under the required units.

Use ↓ to get to Volume Units and then select units of Time and Flow or Velocity.

Flow mode displays flow rate in engineering units (e.g. gpm, litres/sec etc.)

Velocity mode displays flow velocity in units/time (e.g. ft/sec or m/sec)

When all units have been selected go to Store? then ➡ to Yes and ↓ or ↑ to CALIBRATION.

Note: The volume selection "brl" denotes U.S. oil barrel.

CALIBRATION

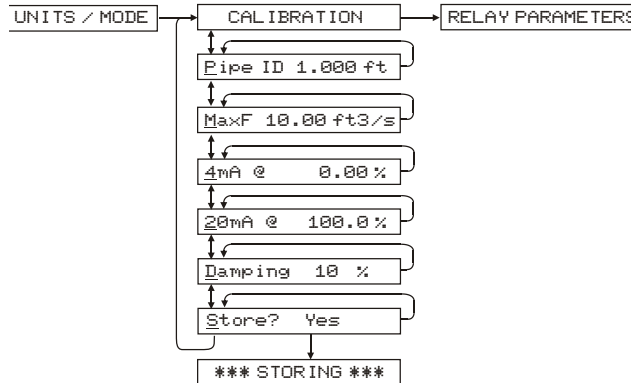

From CALIBRATION press ↓ to Pipe ID and → to place the cursor under the digits and ↓ or ↑ to change the numbers and decimal point. Pipe ID should be entered as the exact inside diameter of the pipe where the sensor is mounted.

Press → to return the cursor to Pipe ID and ↓ to MaxF. Set digits to the maximum flow rate in your application. If maximum flow is unknown, enter an estimated maximum and observe actual flow to determine the correct maximum value. (MaxF entry is required *only* to set 20mA output at a specific flow rate and maximum flow in the optional data logger. MaxF setting has no effect on the DFM-IV digital display, totalizer, or control relays).

4-20mA CURRENT LOOP

Some applications may require the 4-20mA output to be offset so that 4mA or 20mA correspond to flow rates other than Zero and Maximum.

4mA at use ↓ or ↑ to set % output for 4mA. It is adjustable from -5% (3.8mA) up to 15% lower than the 20mA setting. Adjustment resolution is 0.05% (0.01mA).

20mA at use ↓ or ↑ to set % output for 20mA (down to 15% greater than the 4mA setting and up to 300%). Adjustment resolution is 0.05% (0.01mA).

DAMPING

Increase damping to stabilize readings under turbulent flow conditions. Damping time shown in percentage is the interval for a zero to full scale display change (maximum 99 percent). Factory default is 20 percent.

RELAY PARAMETERS

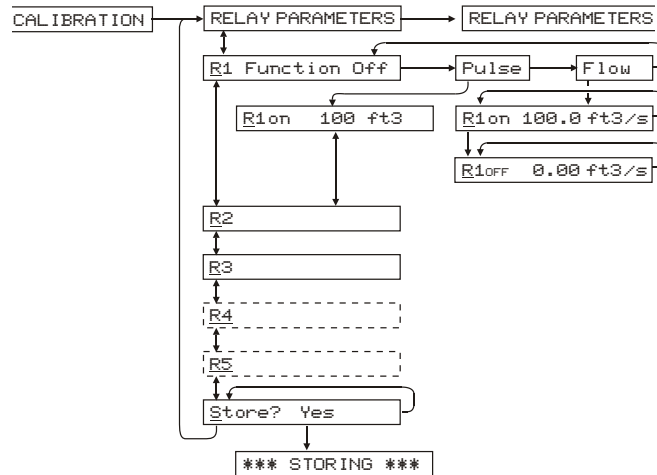

Set Relays 1-3 (4-5 optional) to Off , Pulse or Flow.

Pulse

press **↓** and set digits to the flow volume increment required between relay pulses. Use this feature for remote samplers, chlorinators or totalizers. Maximum pulse setting is 999,999. Minimum time between pulses is 1 second and pulse duration is 350 milliseconds.

Flow

press **↓** and set digits to the required On and Off set points. Use this feature for flow control and alarms.

SPECIAL FUNCTIONS

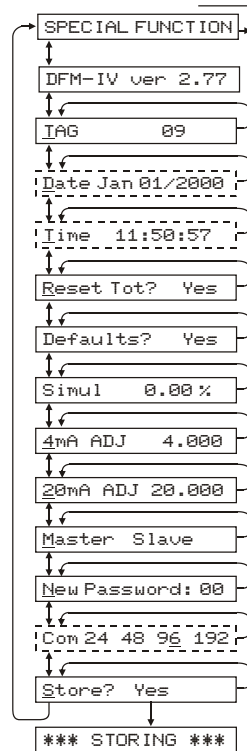

- DFM-IV ver shows software version installed
- Tag enter instrument Tag Number (0-9999)
- Date (with Optional Data Logger) use the ↓ or ↑ keys to change date as required
- Time (with Optional Data Logger) use the ↓ or ↑ keys to change time as required
- Reset Tot? Yes Select Yes to reset totalizer
- Defaults? Yes Press **▶** 3 times to select Yes. Store to erase all user settings and return instrument to factory default settings.
- Simul 0.00% exercises 4-20mA output, digital display and control relays. Simplifies calibration of remote devices on the 4-20mA loop and checks set point/operation of Relays calibrated in Flow mode. Go ↓ for 100%.
- 4mA ADJ Use to fine tune the 4mA and 20mA calibration of the 4-20mA output.
- 20mA ADJ Adjustment range is +1mA to -1mA in 0.002mA steps
Important: The 4-20mA output will be forced to 4mA and 20mA respectively during these adjustments.
- Master or Slave Master or Slave selection for synchronization of multiple DFM-IV flow meters (see Manual section SYNCHRONIZATION).
- New Password position cursor under digits and set new number between 00 and 99
- Com 24 48 96 192 (Optional) set the baud rate of the DFM-IV RS232 output when equipped with an optional data logger.

SENSOR MOUNTING LOCATION

The position of the sensor is one of the most important considerations for accurate Doppler flow measurement. The same location guidelines apply to Doppler as most other types of flow meters.

Before permanently mounting a Doppler sensor onsite testing is recommended to determine optimum mounting position. Use the sensor coupling compound (supplied with each Greyline flow meter, or petroleum gel, acoustic compound or electrocardiograph gel). Take several readings around the axis of the pipe and then at several points upstream and downstream from the selected position, checking for consistent readings. Avoid high or low reading areas. Mount the sensor where consistent (average) readings were obtained or continue testing on another pipe section.

VERTICAL OR HORIZONTAL PIPE - Vertical pipe runs generally provide evenly distributed flow. On Horizontal pipes and liquids with high concentrations of gas or solids, the sensor should be mounted on the side (3 or 9 o'clock position) to avoid concentrations of gas at the top of the pipe, or solids at the bottom. For liquids with minimal gas bubbles (e.g. potable water) the sensor should be mounted on the top of a horizontal pipe (12 o'clock position) to obtain the best signal strength.

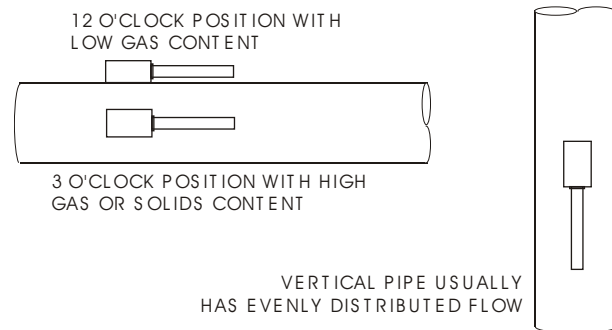

VELOCITY INCREASING DEVICES: Generally the sensor must be mounted away from flow disturbances such as valves, pumps, orifice plates, venturis or pipe inlets and discharges which tend to increase flow velocity. Velocity increasing devices often cause cavitation, or rapid release of gas bubbles, and readings both up and downstream may show much higher velocity. As a guideline, mount the sensor at least 20 diameters upstream or 30 diameters downstream from velocity increasing devices. Required distance from a velocity increasing device will vary in applications depending on the flow velocity and the characteristics of the liquid itself.

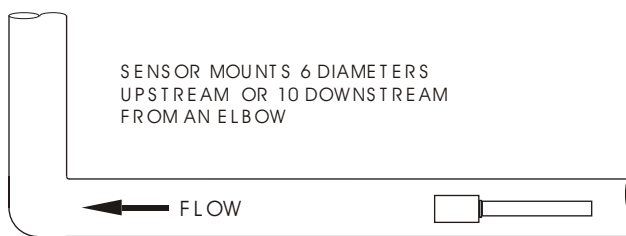

TURBULENCE INCREASING DEVICES: Elbows, flanged connections and tees tend to introduce desirable conditions of an evenly distributed flow profile with some air or gases entrained in the flow. Sensor mounting 6 pipe diameters upstream and 10 diameters downstream from these disturbances is generally optimum.

The sensor is designed to mount longitudinally on a straight section of pipe. Do not attempt to mount it on bends, elbows or fittings.

SENSOR MOUNTING

Prepare an area 2" wide by 4" long (50mm x 100mm) for sensor bonding by removing loose paint, scale and rust. The objective of site preparation is to eliminate any discontinuity between the sensor and the pipe wall, which would prevent acoustical coupling.

A PC3 Sensor Mounting Kit is supplied with each Greyline flow meter. It includes recommended coupling compound in a plastic applicator and a stainless steel mounting bracket with adjustable pipe straps.

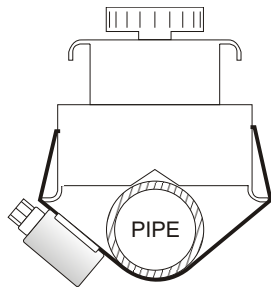

END VIEW

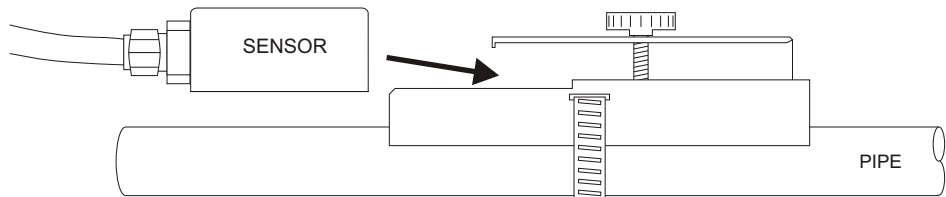

Mount the PC3 pipe clamp as illustrated on pipes 0.6" / 15 mm OD or larger. Stainless steel bands are included for mounting on pipes up to 32" / 81 cm OD.

Additional stainless steel bands (by customer) may be combined to mount on pipes up to 180" / 4.5 m OD.

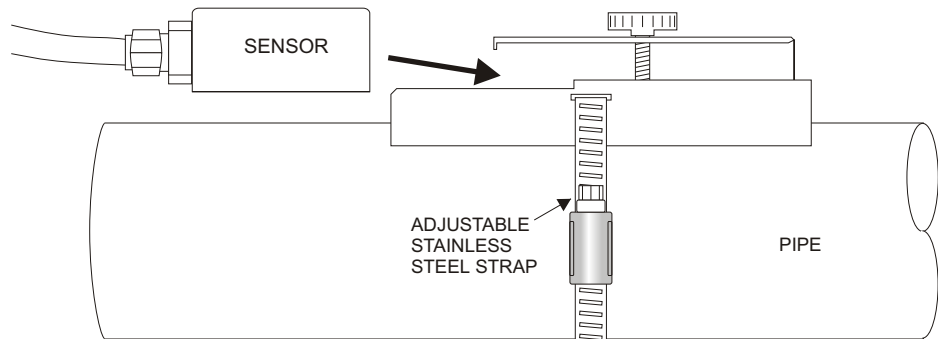
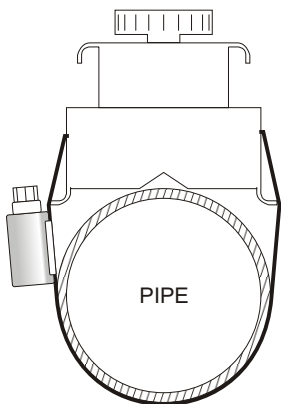

SENSOR COUPLING

For permanent or temporary bonding, the following are recommended:

- a) Dow Corning silicon compound #4 (supplied)

Additional supply: order Greyline Option CC

- b) High Temperature compound (supplied with Sensor Option SE3H)

Additional supply: order Greyline Option AP-1W

- c) Water-based sonic compound: Order Greyline Option CC30
- d) Electrocardiograph gel
- e) Petroleum gel (Vaseline)

The above are arranged in their order of preferred application.

d & e are only good for temporary bonding at room temperature.

DO NOT USE: Silicon RTV caulking compound (silicon rubber).

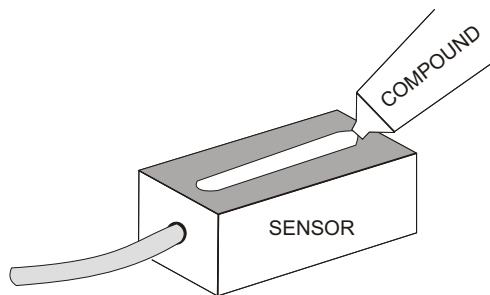

Use the PC3 pipe clamp (supplied) as illustrated above or use a loop of electrical tape for temporary mounting. Apply silicon coupling compound #4 to the coloured face of the sensor. A bead, similar to toothpaste on a toothbrush, is ideal. Do not overtighten (crush the sensor).

The sensor must be fixed securely to the pipe with coupling material between the sensor face and the pipe. Sensor installation with excessive coupling compound can result in gaps or voids in the coupling and cause errors or loss of signal. Insufficient coupling compound will create similar conditions.

Over time temporary coupling compounds (e.g. Petroleum Gel) may gradually sag away from the sensor resulting in reduced signal strength and finally complete loss of signal. Warm temperatures, moisture and vibration will accelerate this process. Dow Corning Silicone Compound #4 as supplied with the DFM-IV (and available from Greyline Instruments) is recommended for semi-permanent installations.

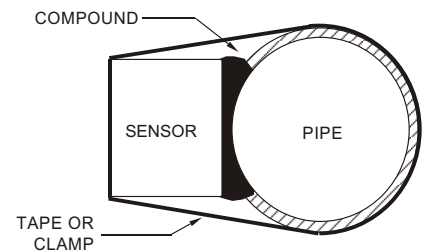

SENSOR MOUNTING/COUPLING RECOMMENDATIONS

BAD

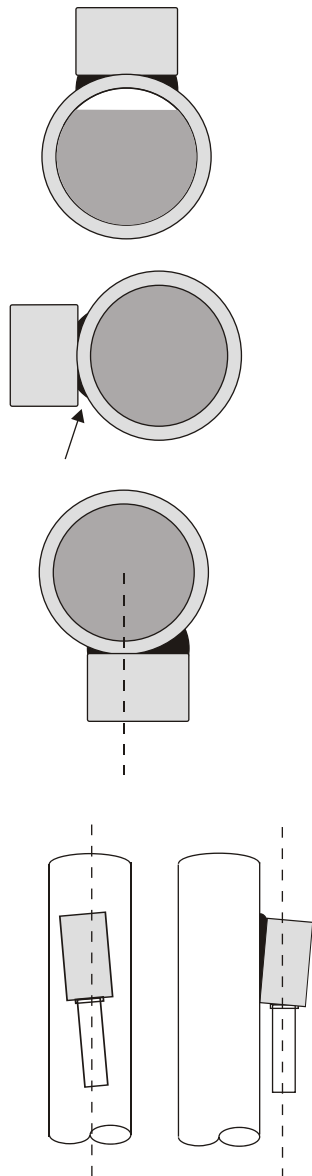

GOOD

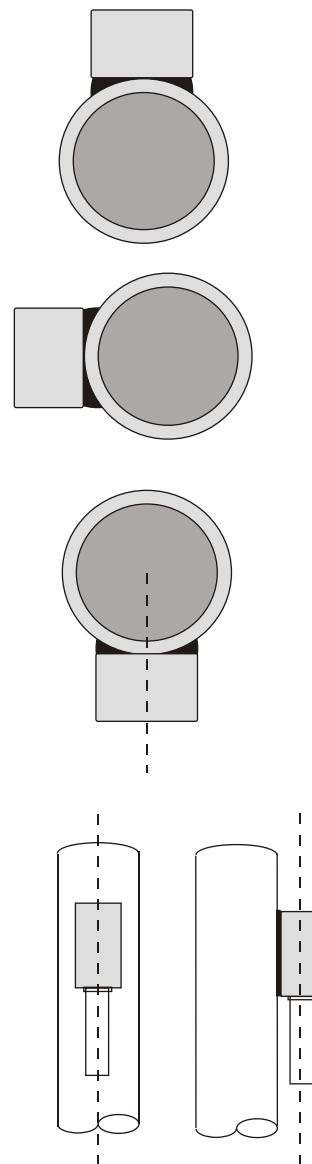

ENCLOSURE INSTALLATION

Locate the enclosure within 20 ft (6 m) of the sensor (500 ft -150 m optional). The enclosure can be wall mounted with the four mounting screws (included) or panel mounted with Option PM Panel Mount kit from Greyline Instruments.

Avoid mounting the enclosure in direct sunlight to protect the electronics from damage due to overheating and condensate. In high humidity atmospheres, or where temperatures fall below freezing, Option TH Enclosure Heater and Thermostat is recommended. Seal conduit entries to prevent moisture from entering enclosure.

NEMA4X (IP66) WITH CLEAR COVER

1. Open hinged enclosure cover.
2. Insert #8 screws (supplied) through the four enclosure mounting holes to secure the enclosure to the wall or mounting stand.

Additional conduit holes can be cut in the bottom of the enclosure when required. Use a hole saw or Greenlee-type hole cutter to cut the required holes.

DO NOT make conduit/wiring entries into the top of the enclosure.

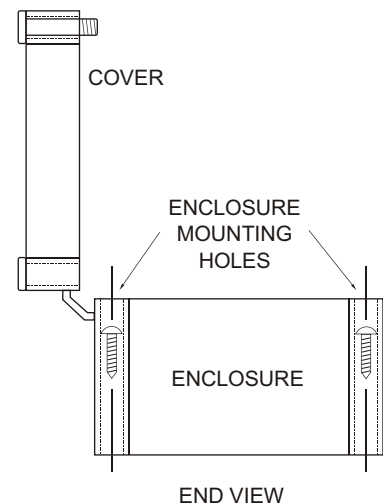

Note: This non-metallic enclosure does not automatically provide grounding between conduit connections. Grounding must be provided as part of the installation. Ground in accordance with the requirements of the National Electrical Code. System grounding is provided by connecting grounding wires from all conduit entries to the steel mounting plate or another point which provides continuity.

SYNCHRONIZATION

Synchronization may be required to prevent interference (readings with no flow or “cross talk”) in applications where more than one DFM-IV Doppler sensor is used in close proximity. Synchronize DFM-IV flow meters if:

- sensors from separate DFM-IV flow meters are mounted on the same pipe
- *extended* sensor cables from separate DFM-IV flow meters are run in the same conduit

To synchronize two or more DFM-IV flow meters:

1. Choose one DFM-IV as a MASTER. Go to the SPECIAL FUNCTIONS menu, select Master and Store? Yes.
2. All other DFM-IV’s must be SLAVES. Go to the SPECIAL FUNCTIONS menu, select Slave and Store? Yes.
3. Connect SYNC + of the “Master” unit to SYNC + of the first “Slave”. Connect SYNC + of the first Slave to SYNC + of the second Slave and so on. Ensure that all units have a common Ground by wiring all GND – terminals together as illustrated:

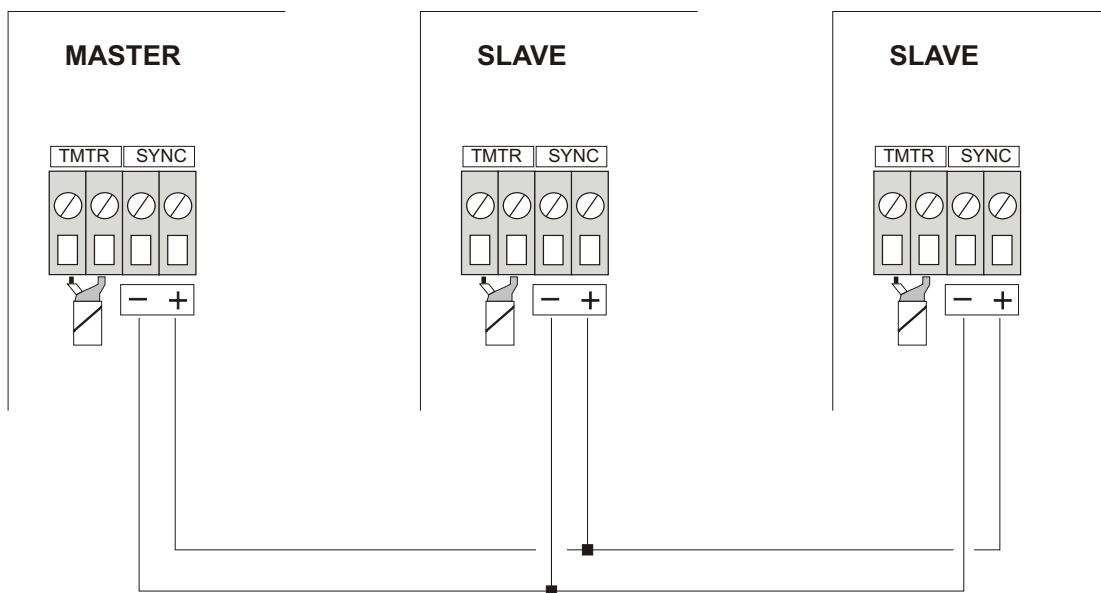

WARNING: Only one DFM-IV in the group can be in “MASTER” mode.
If all units are returned to “MASTER” status, the “SYNC” wiring *must* be disconnected.

BACKFLOW REJECTION

The DFM-IV can be forced to zero under backflow conditions by connecting external, voltage free control relay (dry contacts) to the DFM-IV connection terminals marked INPUT.

Typically the external relay will be energized or de-energized in tandem with a pump or control valve. The external relay *must* be voltage free (the DFM-IV generates a low-voltage DC current across the INPUT terminals). In response to the external relay contact closure the DFM-IV display and outputs will drop to zero, the Totalizer will not increment and the message `Backflow Rejection` will be displayed.

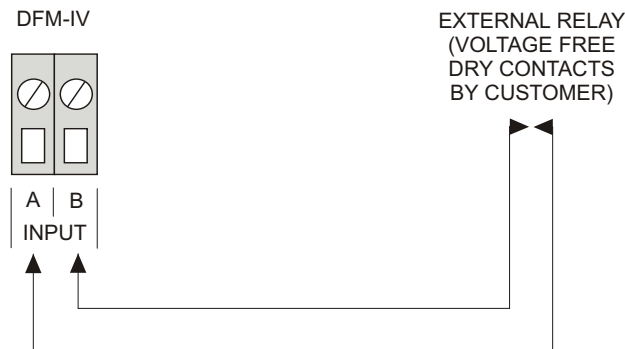

ERROR/WARNING MESSAGES

E: ILLEGAL I.D. The value entered for Pipe ID must be greater than 0.5 inches (1.26 cm) and less than 180 inches (457.3 cm).

E: ILLEGAL MaxF The value entered for MaxF (maximum flow) is too low or too high. Maximum flow value must compute (using pipe ID) a velocity greater than 0.25 ft/sec (0.076 m/sec) or less than 40.0 ft/sec (12.2 m/sec). Refer to Appendix B - Conversion Tables to convert from volume to velocity units.

FUSE REPLACEMENT

1. Turn OFF power
2. Loosen 2 Phillips corner screws and remove power module from the chassis.
3. Locate fuse on Power Board
4. Replace fuse with 2 Amp/250V, 5 x 20mm fuse
5. Reinstall power module in the chassis.

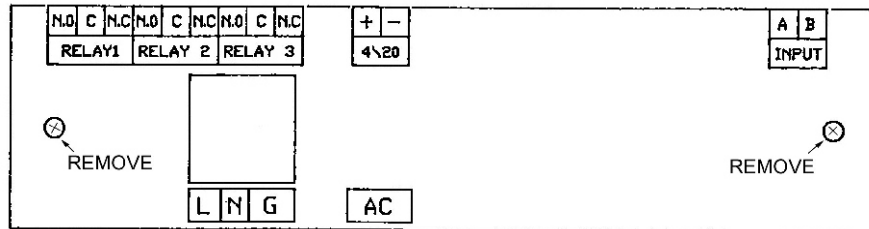

POWER MODULE

FIELD TROUBLESHOOTING

<i>Possible Causes:</i>	<i>Corrective Action:</i>
<i>METER READING LOWER THAN EXPECTED</i>	
Calibration Error	Review UNITS/MODE menu and Pipe ID
Lower flow rate than expected	Investigate pump/valves. Compare velocity with alternate instrument
Signal not penetrating far enough into the flow stream	Increase sensitivity Relocate sensor closer to elbows or flow disturbances
Laminar flow condition or high solids/bubbles content in liquid	Remount Sensor at 12 o'clock position on horizontal pipe
Improper mounting of sensor	Reinstall Sensor with careful application of Coupling Compound
Pipe is not full	Remount Sensor on vertical pipe
<i>METER READING WHEN THERE IS NO FLOW</i>	
Vibration on pipe	Install in another location
Local electrical noise	Ensure all Flowmeter wiring is in METAL conduit and sensor shield is properly grounded. Ensure correct power input Ground connection (<1 ohm resistance). Ensure 4-20mA Shield connected to Instrument Ground stud. Reduce DFM Sensitivity setting.
Cross talk between two or more DFM-IV flowmeters on same pipe	Turn OFF one flowmeter or follow synchronization procedure for two or more DFM-IV Flowmeters.
Variable Speed Drive interference	Follow Drive manufacturers wiring and Grounding instructions Relocate Flowmeter electronics, Sensor and wiring away from VSD

<i>Possible Causes:</i>	<i>Corrective Action:</i>
Valve leak or Reverse flow	Test Valve. Relocate Sensor farther from valve Use Backflow Rejection
Sensor connections incorrect	Refer to Connections diagram
<i>METER READING ERRATIC</i>	
Sensor mounted too close to valve, pump or elbow	Change sensor placement. Recommended 6-10 diameters from elbows, and 30 diameters from pumps, controlling valves, orifice plates, nozzles or open pipe discharge
<i>NO FLOW INDICATION</i>	
SS Signal Strength/Sensitivity set too low	Increase SS/Sensitivity
Not enough suspended particles or gases in the fluid	Relocate sensor in more turbulent pipe section. Mount sensor at 12 o'clock position on horizontal pipe
Coupling compound washed out, or sensor loose on pipe	Remount sensor Use Dow Corning Silicone #4
Slave selected in SPECIAL FUNCTIONS menu with no Synchronization input from Master.	Select Master in SPECIAL FUNCTIONS menu.
Power interruption. No flow.	Check fuse/breaker. Confirm flow
<i>METER READING TOO HIGH</i>	
Calibration error	Review UNITS/MODE menu and Pipe ID
Vibration or noise on the pipeline	Decrease Sensitivity. Install in another location.
Pipe is not full	Remount Sensor on vertical pipe
Nearby velocity increasing device (pump, valve, orifice plate)	Relocate sensor >30 pipe diameters from velocity increasing device
Local electrical noise	Ensure all Flowmeter wiring is in METAL conduit and sensor cable shield is connected to Ground stud

<i>Possible Causes:</i>	<i>Corrective Action:</i>
Variable Speed Drive interference	<p>Follow Drive manufacturers wiring and Grounding instructions</p> <p>Relocate Flowmeter electronics, Sensor and wiring away from VSD</p>
<i>METER READING DOES NOT TRACK FLOW</i>	
Sensor and GND wires reversed or not properly connected	Check Sensor connections
Improper AC power input Ground	Use direct connection with 12 AWG wire to nearest Ground pole (<1 ohm resistance).

COMMON QUESTIONS AND ANSWERS

The pipe vibrates. Will it affect the flow meter?

Common vibration frequencies are far lower than the sonic frequencies used by the Greyline flow meter, and will not normally affect accuracy or performance. However, applications where very weak Doppler signal is present (when sensitivity is adjusted to maximum and signal strength is low), accuracy may be affected by pipe vibration, or the flow meter may show readings under no-flow conditions. Attempt to relocate the sensor on a pipe section where vibration is reduced, or arrange pipe mounting brackets to reduce vibration at the sensor mounting location.

The flow meter must be installed in a high noise environment. Will this affect operation?

Greyline flow meters are designed to discriminate between environmental noise and the Doppler signal. High noise environments may affect the flow meter's performance where low signal strength and/or low flow velocities are being measured. If adjustment of the flow meter sensitivity does not eliminate noise interference a non-acoustic flow meter should be considered for the application.

Will pipe corrosion affect accuracy of the flow meter?

Yes. Rust, loose paint etc. must be removed from the outside of the pipe to provide a clean mounting position when installing a Doppler sensor. Severe corrosion/oxidation on the inside of the pipe may prevent the Doppler signal from penetrating into the flow. If the pipe cannot be cleaned, a spool piece (PVC recommended) should be installed for sensor mounting.

What effect do pipe liners have on the flow meter?

The air gap between loose insertion liners and the pipe wall prevent the Doppler signal from entering the flow. Better results can be expected with bonded liners such as cement, epoxy or tar, however an on site test is recommended to determine if the application is suitable for a Doppler flow meter.

Why is Doppler only recommended for liquids containing suspended solids or gases?

The Doppler sensor transmits sound into the flow stream which must be reflected back to the sensor to indicate flow velocity. Gas bubbles or suspended solids act as reflectors for the Doppler signal. As a guideline, Greyline Doppler flow meters are recommended for liquids containing solids or bubbles with a minimum size of 100 microns and a minimum concentration of 75 ppm. Most applications (except potable, distilled or deionized water) will meet this minimum requirement.

Can the sensor be submerged in water?

Yes, for short periods of time or by accident, but not for continuous operation. The sensor is constructed to withstand submersion to 10 psi without damage, but external liquid moving in contact with the sensor can be interpreted as flow and cause false readings.

What is the purpose of the Signal Strength Display and Sensitivity adjustment?

Doppler signals of low strength (left of the ✕ on the SS signal strength display) are not accepted or processed by the instrument. This feature assists in rejection of environmental noise and vibration. For optimum noise rejection the sensitivity control should be adjusted so that signal strength is to the right of the ✕ on the signal strength display with flow and to the left of the ✕ with no flow.

Can I change the length of the sensor cable?

Yes. Technological advances in Greyline Doppler design allow cable lengths up to 500 ft (152 m) with no loss of signal strength. Extended cable (Greyline Option XC) should be installed in rigid or flexible conduit for mechanical protection. Use only Greyline shielded coaxial pair (RG174U) cable. Cable junctions should be made through a terminal block and housed in a watertight metal junction box (Greyline Option JB). BNC coaxial connectors (TV cable type) are not recommended for cable splices.

Does the DFM-IV require periodic recalibration?

No. DFM-IV calibration does not drift over time. The solid state sensor has no moving parts to wear and affect calibration. The Doppler flow technique generates an ultrasonic signal proportional to the velocity of flow. All Greyline timing/counting circuits use crystal-controlled frequency references to eliminate any drift in the processing circuitry.

APPLICATIONS HOTLINE

For applications assistance, advice or information on any Greyline Instrument contact your Sales Representative, write to Greyline or phone the Applications Hotline below:

United States:	Tel: 315-788-9500	Fax: 315-764-0419
Canada:	Tel: 613-938-8956	Fax: 613-938-4857
Toll Free:	888-473-9546	
Email:	info@greyline.com	
Web Site:	www.greyline.com	

Greyline Instruments Inc.

Canada
16456 Sixsmith Drive
Long Sault, Ont. K0C 1P0

USA:
105 Water Street
Massena, NY 13662

PRODUCT RETURN PROCEDURE

Instruments may be returned to Greyline for service or warranty repair.

1 Obtain an RMA Number from Greyline -

Before shipping a product to the factory please contact Greyline by telephone, fax or email to obtain an RMA number (Returned Merchandise Authorization). This ensures fast service and correct billing or credit.

When you contact Greyline please have the following information available:

1. Model number / Software Version
2. Serial number
3. Date of Purchase
4. Reason for return (description of fault or modification required)
5. Your name, company name, address and phone number

2 Clean the Sensor/Product -

Important: unclean products will not be serviced and will be returned to the sender at their expense.

1. Rinse sensor and cable to remove debris.
2. If the sensor has been exposed to sewage, immerse both sensor and cable in a solution of 1 part household bleach (Javex, Clorox etc.) to 20 parts water for 5 minutes. Important: do not immerse open end of sensor cable.
3. Dry with paper towels and pack sensor and cable in a sealed plastic bag.
4. Wipe the outside of the enclosure to remove dirt or deposits.
5. Return to Greyline for service.

3 Ship to Greyline -

After obtaining an RMA number please ship the product to the appropriate address below:

*Canadian and International
Customers:*

Greyline Instruments Inc.
16456 Sixsmith Drive
Long Sault, Ont. K0C 1P0

RMA#

USA

Customers:

Greyline Instruments Inc.
105 Water Street
Massena, NY 13662

RMA#

FLOW METER DATA SHEET

<p>Greyline Instruments Inc.</p> <p><input type="checkbox"/> 16456 Sixsmith Dr., Long Sault, Ont. K0C 1P0 Tel: 613-938-8956 / Fax: 613-938-4857</p> <p><input type="checkbox"/> 105 Water Street, Massena NY 13662 Tel: 315-788-9500 / Fax: 315-764-0419</p>	<p><i>Please complete and return this form to Greyline. It is important. We use this information to check our database for performance of Greyline flow meters in similar applications, and to provide advice and recommendations to you. Thanks for your cooperation.</i></p>
<p>Contact: _____ Title/Dept.: _____</p> <p>Company: _____ Project: _____</p> <p>Address: _____</p> <p>Tel: _____ Fax: _____</p>	
<p>SENSOR:</p> <p>Model/Type: _____ Cable Length: _____</p> <p>Elec. Class: _____ Type of Pump: _____</p> <p>Distance from nearest Pump, Controlling Valve, Orifice or open Discharge: _____</p>	
<p>INSTRUMENT:</p> <p>Model/Type: _____ Power Input: _____</p> <p>Calibrated Range: _____ Indication: _____</p> <p>Operating Temp.: _____ Alarm: _____</p> <p>Enclosure Class: _____ Pulse/Unit: _____</p> <p>Elec. Class: _____ Output: _____</p>	
<p>SERVICE CONDITIONS:</p> <p>Pipe ID: _____ <input type="checkbox"/> Vertical <input type="checkbox"/> Horizontal</p> <p>Pipe Mat'l: _____ % Solids: _____</p> <p>Fluid: _____ Material Build-up: _____</p> <p>Oper. Flow: _____ Vibration: _____</p> <p>Max. Flow: _____ Max. Pressure: _____</p> <p>Min. Flow: _____ Max. Temp: _____</p>	
<p>Notes / Sketch Pipe Run:</p>	
<p>By: _____ Date: _____</p>	

LIMITED WARRANTY

Greyline Instruments warrants, to the original purchaser, its products to be free from defects in material and workmanship for a period of one year from date of invoice. Greyline will replace or repair, free of charge, any Greyline product if it has been proven to be defective within the warranty period. This warranty does not cover any expenses incurred in the removal and re-installation of the product.

If a product manufactured by Greyline should prove defective within the first year, return it freight prepaid to Greyline Instruments along with a copy of your invoice.

This warranty does not cover damages due to improper installation or handling, acts of nature, or unauthorized service. Modifications to or tampering with any part shall void this warranty. This warranty does not cover any equipment used in connection with the product or consequential damages due to a defect in the product.

All implied warranties are limited to the duration of this warranty. This is the complete warranty by Greyline and no other warranty is valid against Greyline. Some states do not allow limitations on how long an implied warranty lasts or limitation of incidental or consequential damages, so the above limitations or exclusions may not apply to you.

This warranty gives you specific legal rights, and you may also have other rights which vary from state to state.

Greyline Instruments Inc.

APPENDIX A – OPTIONS

**EXTRA SENSOR CABLE
(OPTION DXC)**

Each Greyline flow meter includes 20 ft / 6m (or 50 ft / 15 m optional) continuous shielded coaxial pair cable. Additional cable and Cable Junction Box (Option DJB) may be ordered with the Flow Meter, or the cable may be spliced and extended up to 500 ft (152m) as required during installation. No adjustment is required when the sensor cable is extended or shortened. Use only Greyline shielded coaxial pair (RG174U) cable.

Extended sensor cable should be installed in conduit for mechanical protection. Recommended installation with a metal junction box (Option DJB) is illustrated below:

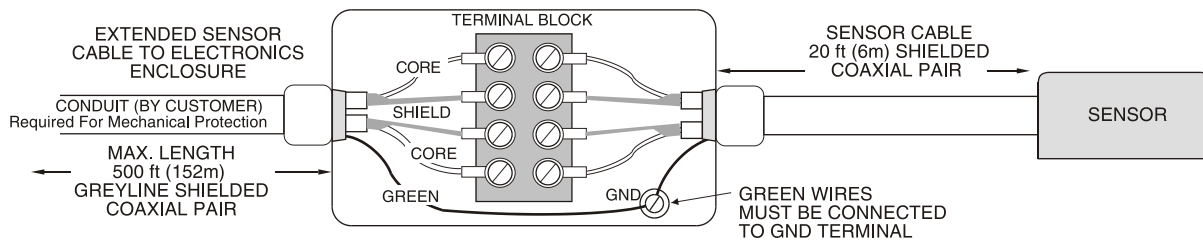

COAXIAL CABLE PREPARATION

DXC Doppler sensor cable can be cut and spliced up to a maximum length of 500 ft (152 m). Cable ends must be prepared as illustrated below.



**SENSOR CABLE JUNCTION BOX
(OPTION DJB)**

Optional Watertight steel NEMA4 Junction Boxes with terminal strips are available from Greyline Instruments.

**DIMENSIONS
OPTION DJB - JUNCTION BOX**

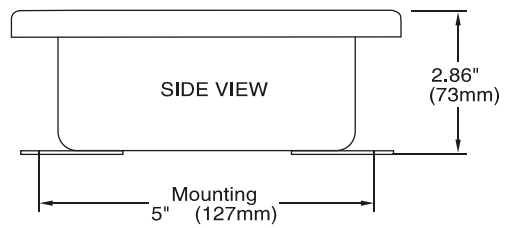
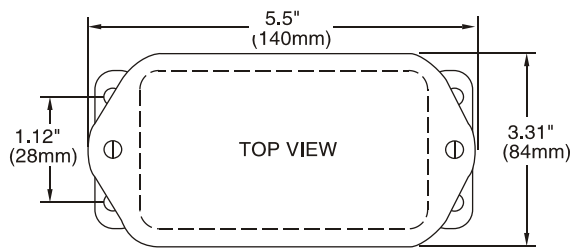

SENSOR INTRINSIC SAFETY (OPTION 2ISB)

When connected through Intrinsic Safety Barriers, the Greyline Sensor Model SE3 is CSA certified for installation in a hazardous location rated:

- Class I, Groups C,D
- Class II, Groups E,F,G
- Class III

Intrinsic Safety Barriers may be ordered with the Greyline instrument and are supplied mounted in the Greyline instrument enclosure. Replacement barrier fuses (Part No. ISB- 011239) may be purchased separately. The Instrument Enclosure containing the 2ISB Intrinsic Safety Barriers must be installed in a non-hazardous location. The Sensor, connecting cable and Junction boxes may be located in the hazardous rated area.

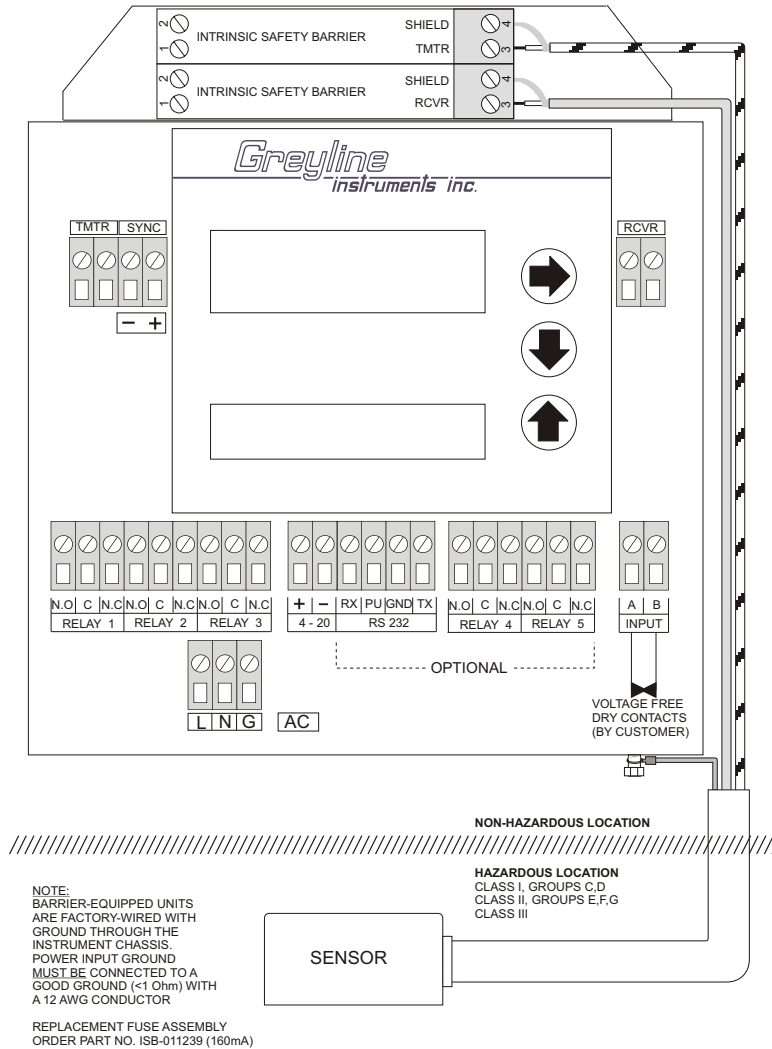

Intrinsic Safety Barrier Specifications: Certified, rated 9.3V max, 25 ohms min. (Recommended: Stahl Model 9001/02-093-390-10).

ENCLOSURE HEATER AND THERMOSTAT - Option TH

Instruments can be factory-equipped with an Enclosure Heater and Thermostat. The Thermostat is factory set to turn ON at 40°F (4.5°C) and OFF at 60°F (15.5°C). Power consumption is 15 Watts.

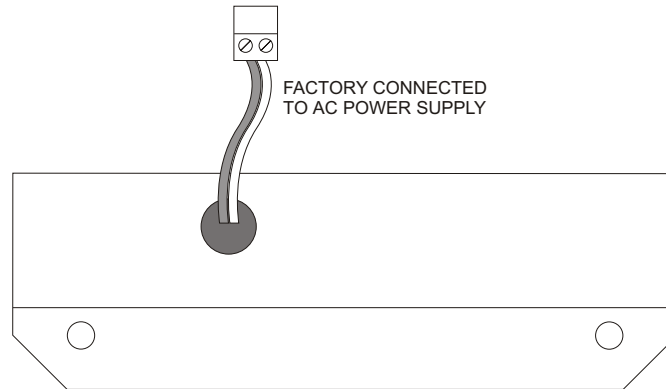

ENCLOSURE SUNSCREEN - Option SCR

Do not mount instrument electronics in direct sunlight. Overheating will reduce the life of electronic components and condensate may form during the heat/cool cycles and cause electrical shorts.

Note:

Exposure to direct sunlight can cause overheating and moisture condensation which will reduce the operating life of electronics.

Protect Instruments from direct sunlight with this iridite finished aluminum sun screen (Greyline Option SCR).

Seal conduit entries with caulking compound to further reduce moisture condensation.

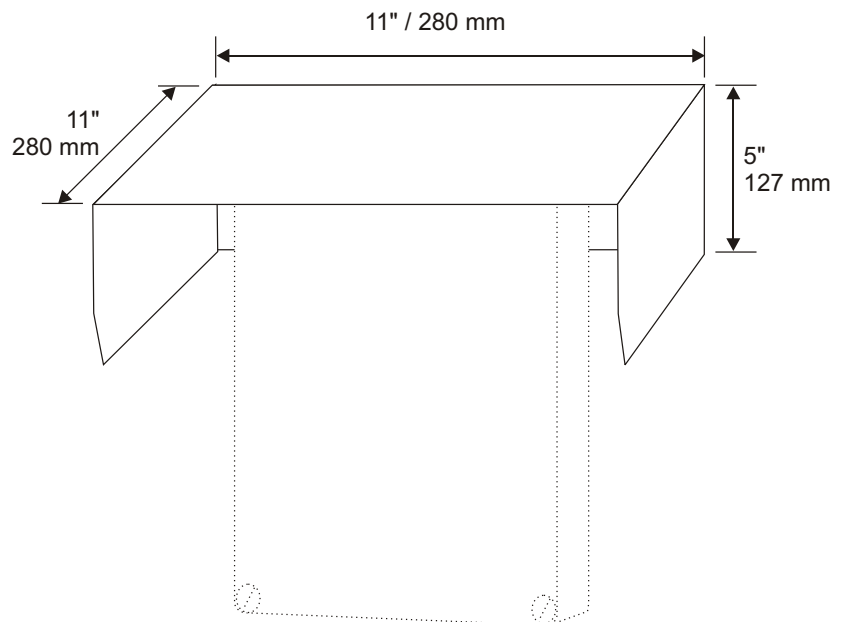

**POWER INPUT OPTION
12VDC OR 24VDC**

DFM-IV Flow Meters may be ordered factory-configured for 12VDC, or 24VDC power input.

QUICK BENCH TEST:

Connect Sensor as shown below, then Power. Test operation of the DFM-IV by holding the sensor in one hand and rubbing your thumb or fingers briskly across the face (plastic surface) of the sensor. Allow 15 seconds for the DFM-IV to process the signal and display a flow value.

CONNECTIONS:

POWER INPUT: Connect only 12VDC/0.54 Amps to the + and - terminals for units marked 12V, or 24VDC/0.27 Amps for units marked 24VDC. The Power Input GND terminal must be connected to the nearest Ground pole. A 1 amp fuse in line is recommended. Power Consumption is 6.5 W continuous.

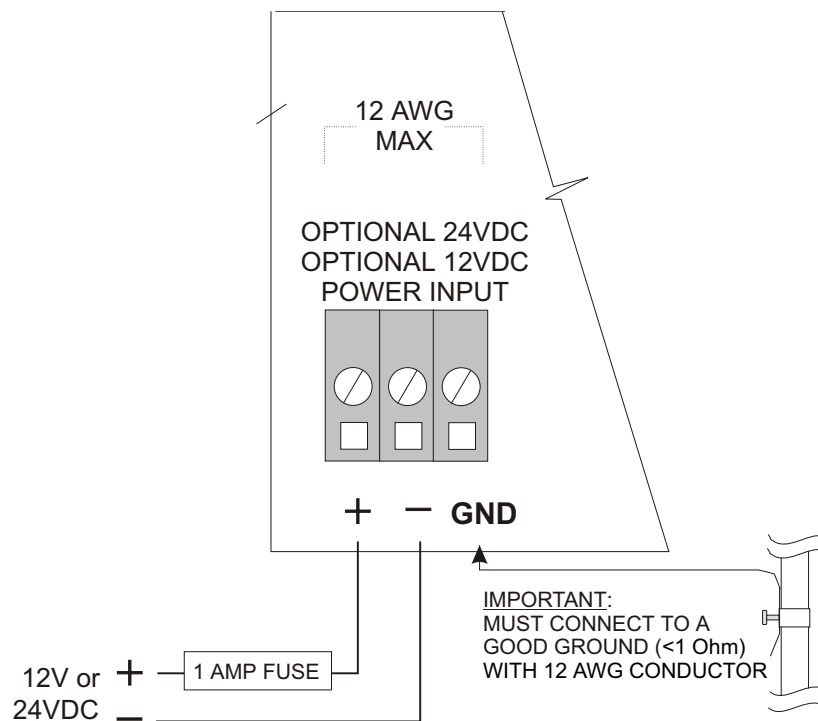

**INSERTION FLOW SENSOR
(OPTION ISE)**

Insertion Depth: 1/8th pipe inside diameter plus 3/4" (20 mm).

Orientation: Screw head marks the active face and should point upstream ±5°.

Average Flow Rate: Before permanent tightening of swage lock fitting, the probe can be inserted to variable depths to determine the flow profile. Theoretical average flow occurs at 1/8 pipe diameter.

Installation Procedure: Install a 1" NPT Female Nipple on the Pipe. Insert probe. Tighten swage lock until it just grips the Probe - then tighten 3/4 of a turn. Do not use above 100 psi.

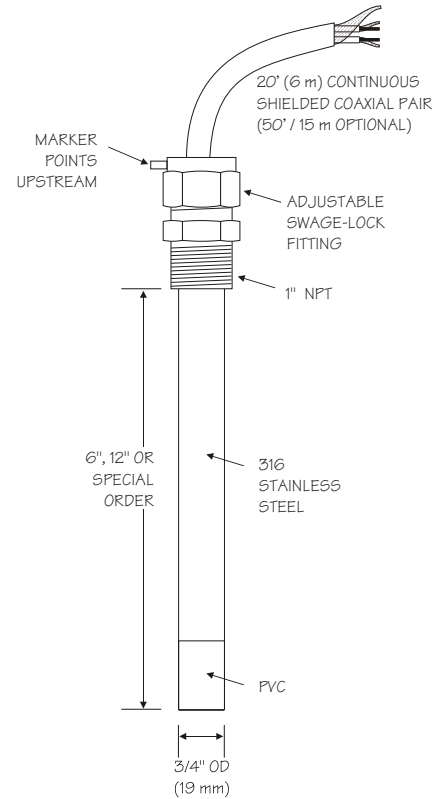

**HIGH TEMPERATURE SENSOR
(OPTION SE3H)**

Mount with coupling compound and stainless steel pipe clamp (supplied). Protect Sensor cable from contact with hot pipes.

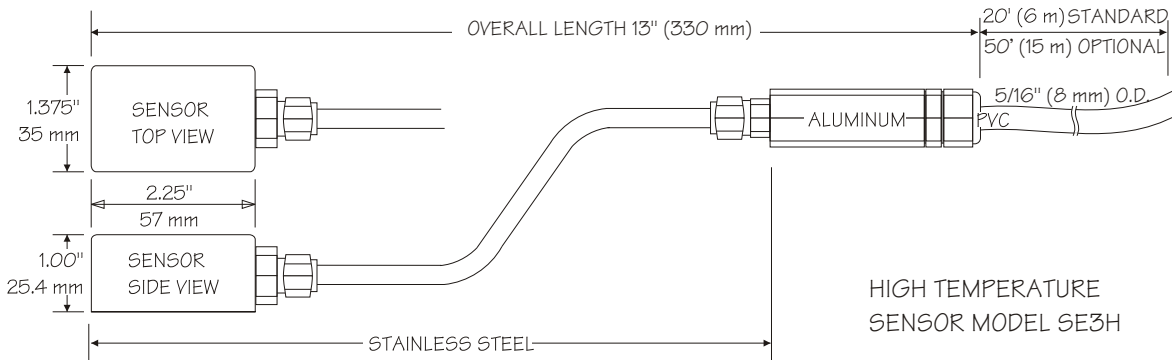

SE3H Specifications:

- Operating Temperature: -40° to 302°F (-40° to 150°C)
- Minimum Pipe Diameter: 0.5" (12.5 mm) ID, 0.6" (15 mm) OD
- Maximum Pipe Diameter: 180" (4.5 m) O.D.
- Operating Frequency: 640 KHz
- Exposed Materials: stainless steel with epoxy face
- Sensor Cable: 20 ft (6 m) RG174U shielded coaxial pair

Data Logger Menu (Optional)

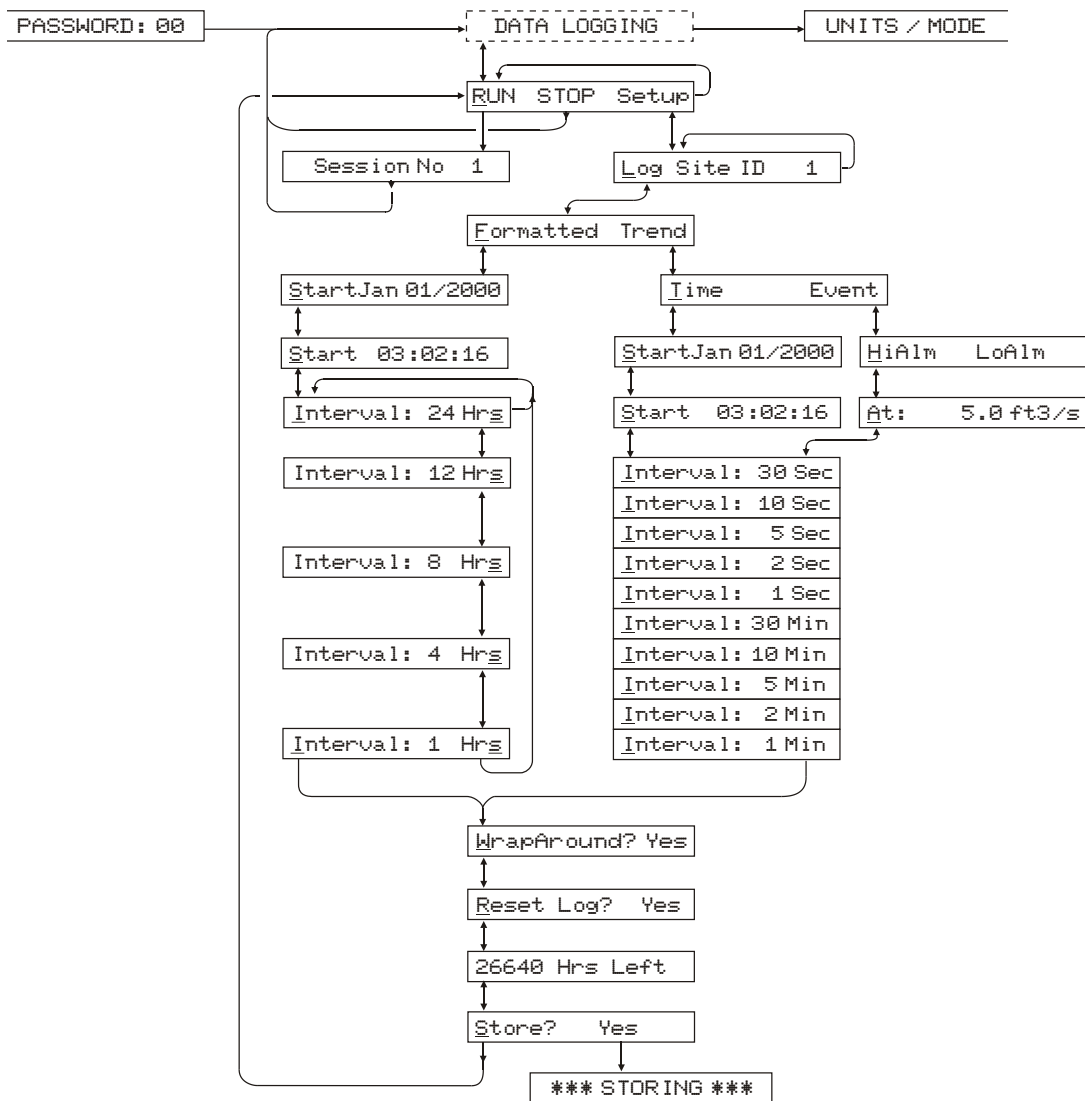

DATA LOGGING (Optional)

Setup

From RUN STOP SETUP press **➡** to SETUP and then **⏴** to Log Site ID **0**. Press **➡** to position the cursor under the numeral and **⏴** or **⏵** to change the numerals. The “Site ID” number is retained with data logging sessions to identify logs stored from different locations.

Formatted Data

Press **⏴** from Log Site ID and press **⏴** from Formatted.

“Formatted” data stores a summary of flow readings over a user-selectable time period. The summary includes:

DATE and TIME
Interval TOTAL
Interval AVERAGE
Interval MAX FLOW
Interval MAX FLOW TIME
Interval MIN FLOW
Interval MIN FLOW TIME

From Formatted press **⏴** to Start MMM DD/YYYY (eg: Jan 01/2000). Press **➡** to position the cursor and then **⏴** or **⏵** to set the Month, Day and Year that logging will Start. Press **➡** to return to Start.

Press **⏴** to Start (time) and **➡** to position the cursor under the time column HH/MM/SS (24 hour clock in Hours/minutes/seconds, eg: 23:02:16) and then **⏴** or **⏵** to set the logging start Time. Press **➡** to return to Start.

Press **⏴** to Interval and **➡** to the Hrs column. Press **⏴** or **⏵** to select the flow logging interval. Choose from:

24 Hrs, or 12 Hrs, or 8 Hrs, or 4 Hrs, or 1 Hrs

Press **➡** to return to Interval. Press **⏴** and the DFM-IV will report xxxxx Hrs Left indicating the amount of logging time available with your current set-up. You can also press **⏵** to return to previous menu items and make changes.

Press **⏴** to WrapAround Yes?. Press **➡** to Yes? and **⏴** to enable the logging wrap function. In WrapAround mode the *oldest* data will be overwritten by the *newest*. If WrapAround is not enabled the logger will stop when its memory becomes full.

Press ↓ to Reset Log? Yes. Press → to Yes and then ↓ to reset the Log and erase all previous sessions and stored values. Or press ↓ from Reset Log? to retain existing data in the Log. The DFM-IV will display “xxxxx Hrs/Days Left”.

From the xxxxx Hrs Left display press ↓ to Sore? Yes. Press → to Yes and then ↓ to save your Data Logging setup, or press ↓ from Sore? to cancel changes made above and exit without storing changes.

From the Data Logging Store? Yes prompt the menu will return to RUN STOP SETUP. Press → to position the cursor under RUN and press ↓ to activate the Data Logger to start at your selected start Date and Time. The DFM-IV will display SESSION NO. x. Press ↓ to return to DATA LOGGING.

Viewing FORMATTED Data Logs on the DFM-IV Display

24 Hour Formatted logs can be viewed directly on the DFM-IV display. From RUN press → to 24 HR LOG. This function is available only if 24 Hour Formatted logging has been Stored from the DATA LOGGING menu.

The 24 Hour Log Report is designed to be read one line at time using the → key. Using the ↓ or ↑ keys will return the display to the Date column.

TODAYS DATE	DAILY TOTAL	DAILY AVERAGE	MAX FLOW	MAX FLOW TIME	MIN FLOW	MIN FLOW TIME
PREVIOUS DATE	“	“	“	“	“	“
PREVIOUS DATE	“	“	“	“	“	“
PREVIOUS DATE	“	“	“	“	“	“
PREVIOUS DATE	“	“	“	“	“	“
PREVIOUS DATE	“	“	“	“	“	“

The current day plus the past 255 days of data can be displayed. (Greyline Logger software will display up to 1300 days of data.)

Trend Data Logging - Setup

From RUN STOP SETUP press → to SETUP and then ↓ to Log Site ID 0. Press → to position the cursor under the numeral and ↓ or ↑ to change the numerals. The “Site ID” number is retained with data logging sessions to identify logs stored from different locations.

From Log Site ID press ↓ to Formatted Trend and press → to position the cursor under Trend. Then press ↓ to select Time based logging.

‘Time’ based Trend Logging

Time based logging allows you to choose Start and Stop times and a logging interval.

From Time press ↓ to Start MMM DD/YYYY (eg: Jan 01/2000). Press → to position the cursor and then ↓ or ↑ to set the Month, Day and Year that logging will Start. Press → to return to Start.

Press ↓ to Start (time) and → to position the cursor under the time column HH/MM/SS (24 hour clock in Hours/minutes/seconds, eg: 23:02:16) and then ↓ or ↑ to set the logging start Time. Press → to return to Start.

Press ↓ to Interval and → to the Sec/Min column. Press ↓ or ↑ to set the logging time interval. Choose:

30 Sec
10 Sec
5 Sec
2 Sec
1 Sec
30 Min
10 Min
5 Min
2 Min
1 Min

Press → to return to Interval and ↓ to Reset Log? To erase all existing data in the log press → to Yes and ↓. To keep existing data in the Log press ↓ from Reset Log? If you have made changes to the Start Date, Time or Interval, the data logger will automatically start a new “session”. The DFM-IV will display “xxxxx Hrs/Days Left”.

From the xxxxx Hrs Left display press ↓ to Store? Yes. Press → to Yes and then ↓ to save your Data Logging setup, or press ↓ from Store? to cancel changes made above and exit without storing changes.

From the Data Logging Store? Yes prompt the menu will return to RUN STOP SETUP. Press → to position the cursor under RUN and press ↓ to activate the Data Logger to start at your selected start Date and Time. The DFM-IV will display SESSION NO. x. Press ↓ to return to DATA LOGG ING.

‘Event’ based Trend Logging

Event based logging stores data points only when a High or Low flow set point has been reached.

With cursor under Event press ↓ to HiAlm LoAlm. HiAlm will log points *above* a selectable flow rate, while LoAlm will log points *below* a selectable flow rate. Position the cursor under HiAlm or LoAlm and press ↓ to the set: prompt. Press → to the numerals column and press ↓ or ↑ to set flow alarm logging set point. Press → to return to set:.

Press ↓ to Interval and → to the Sec/Min column. Press ↓ or ↑ to set the logging time interval.

Choose:

30 Sec
10 Sec
5 Sec
2 Sec
1 Sec
30 Min
10 Min
5 Min
2 Min
1 Min

Press → to return to Interval and press ↓ to Reset Log? To erase all existing data in the log press → to Yes and ↓. To keep existing data in the Log press ↓ from Reset Log? If you have made changes to the Start Date, Time or Interval, the data logger will automatically start a new "session". The DFM-IV will display "xxxxx Hrs/Days Left".

From the xxxxx Hrs Left display press ↓ to Store? Yes. Press → to Yes and then ↓ to save your Data Logging setup, or press ↓ from Store? to cancel changes made above and exit without storing changes.

From the Data Logging Store? Yes prompt the menu will return to RUN STOP SETUP. Press → to position the cursor under RUN and press ↓ to activate the Data Logger to start. The DFM-IV will display SESS ION NO. x. Press ↓ to return to DATA LOGG ING.

Note: Greyline Logger software cannot accurately calculate totals from 'event' based log files. Use 'trend' logging format if totals must be calculated.

Logging "Sessions"

Each time you select STOP in the DATA LOGGING menu, the Data Logger stores the current data in memory as a "SESSION NO" automatically numbered from "1" to "10". If you resume logging by selecting RUN, the Data Logger will report that a new logging session is started and titled "SESSION NO xx". When you download the logger files to your PC using Greyline Logger software, each Session will open as a separate graph/table titled "Greyline Data Log xx".

Important:

If you STORE instrument calibration changes under the UNITS/MODE or CAL IBRATION menus, STOP the data logger and select RUN again to start a new logging Session with your new calibration values.

RS232C SERIAL OUTPUT (with optional Data Logger)

Format: 8 Bits, 1 Stop Bit, No Parity. (Baud rate may be changed under the SPECIAL FUNCTIONS menu. Factory default is 19200 baud).

Output connector is DB9-Female. Use the cable supplied for connection to a PC Computer. Use the cable and optional Null Modem NM-DB9M/DB25M for connection to a modem.

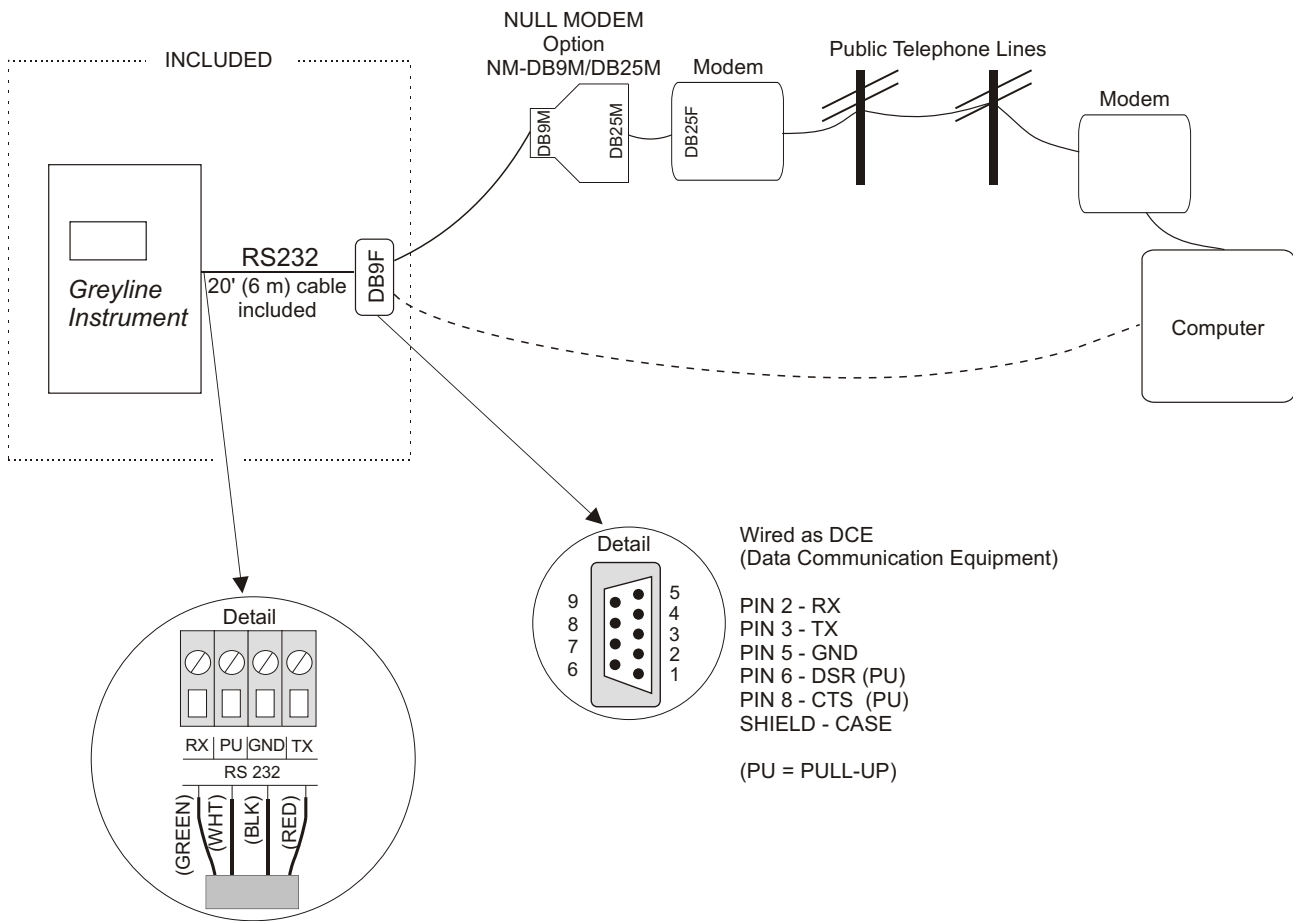

RS485 SERIAL OUTPUT
(Replaces standard RS232 Output with Data Logger option.)

Permits transfer of optional Data Logger reports on wire lengths up to 4000 ft. (1220 m).
Format: 8 Bits, 1 Stop Bit, No Parity. (Baud rate may be changed under the SPECIAL FUNCTIONS menu. Factory default is 19200 baud).

Use shielded, 4-conductor cable (Greyline cable option SC-18AWG recommended). Connect the cable shield to Ground at the DFM-IV electronics enclosure and *do not* connect to Ground at the other end.

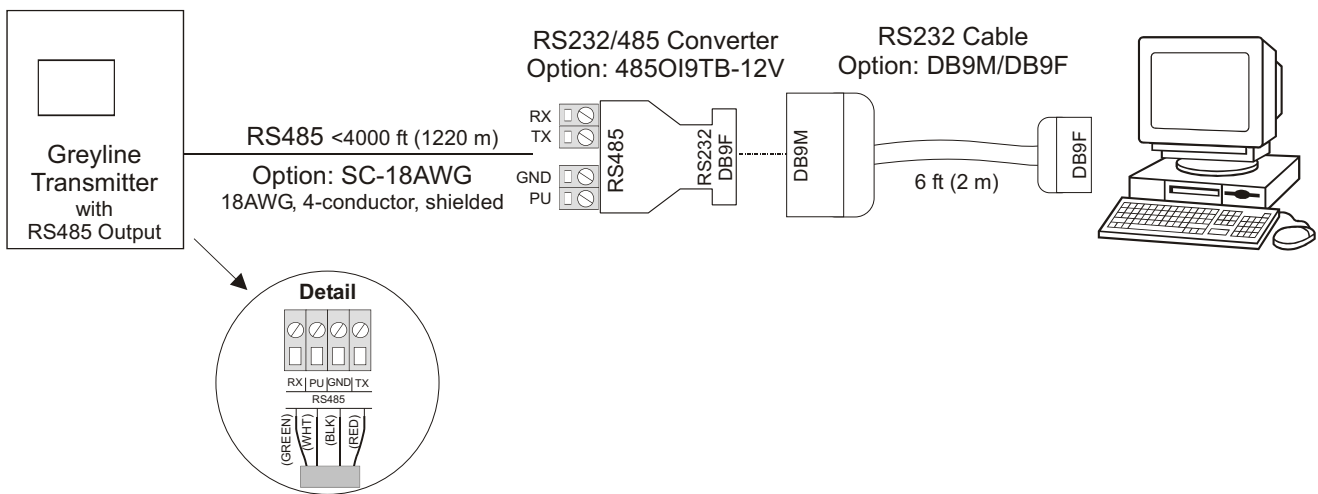

Configure the Greyline software program for RS485 communications. Under the Communications / Connection Setup menu, select 'Connected to a Greyline 485OI-12V adaptor'.

485OI9TB-12V
RS232/RS485 Converter

Use with optional RS485 output for connection to a PC computer or modem.

- Optically isolates and protects your computer's RS232 port
- Terminal block for RS485 connections
- Operates from 2400 up to 19.2K baud

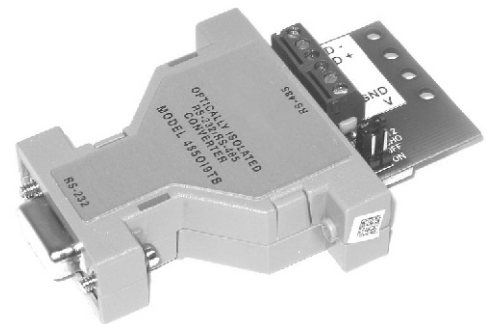

DB9M/DB9F - RS232 Cable
Connects RS232/485 Converter to a PC

Cable length 6 ft. (2 m) with DB9M and DB9F connectors.

SPECIFICATIONS

- Flow Rate Range:** 0.25 to 40 ft/sec ((0.08 to 12.2 m/sec) in most applications
- Pipe Size:** Any pipe ID from 0.5" to 180" (12.5 mm to 4.5 m)
- Accuracy:** ±2% of full scale. Requires solids or bubbles minimum size of 100 microns, minimum concentration 75 ppm. Repeatability: ±1%, Linearity ±0.5% of full scale
- Displays:** Flow Rate – large, 4-digit LCD in programmable engineering units
Totalizer/Menu/Status/Signal Strength – 16-digit LCD, alphanumeric
- Calibration:** built-in 3-key calibrator, No-drift transmitter: quartz crystal frequency reference
- Power Input:** 100-130VAC, 50/60 Hz, (7.2 W max.)
Optional: 200-260VAC, 50/60 Hz, (7.2 W max.)
Optional: 12VDC or 24VDC, (6.5 W max.)
- Power Consumption:** 120VAC 0.06 amps (7.2 W); 240VAC 0.03 amps (7.2 W);
24VDC 0.27 amps (6.5 W); 12VDC 0.54 amps (6.5 W)
(Relays Off reduces by 1 W; 4-20mA disconnected reduces by 0.5 W)
- Output:** Isolated 4-20mA (1000 ohm load max.)
- Control Relays:** Qty 3, rated 5 amp SPDT, programmable flow alarm and/or proportional pulse forces display and outputs to zero with contact closure from remote relay
- Back Flow Rejection:** watertight, dust tight NEMA4X (IP66) fiberglass with a clear shatter-proof face
- Enclosure:** watertight, dust tight NEMA4X (IP66) fiberglass with a clear shatter-proof face
- Electronics Operating Temp:** -10 to 140 F (-23 to 60 C)
- Sensitivity:** adjustable. Damping: adjustable
- Electrical Surge Protection:** Sensor, 4-20mA output and AC power input

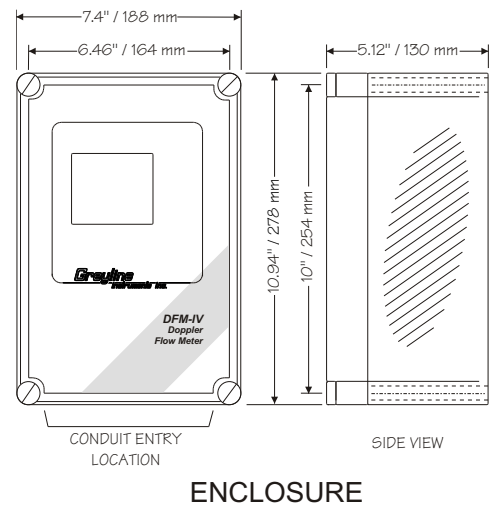

SE3 Doppler Sensor

- Minimum Pipe Diameter:** 0.5" (12.5 mm) ID, 0.6" (15 mm) OD
- Maximum Pipe Diameter:** 180" (4.5 m) ID
- Operating Temperature:** -40 to 200 F (-40 to 93 C)
- Operating Frequency:** 640 KHz
- Sensor Housing:** Stainless Steel with Epoxy face
- Sensor Cable:** 20 ft. (6 m) shielded coaxial pair (RG174U)
Optional 50 ft (15 m) continuous
- Submersion Rating:** Withstands accidental submersion pressure up to 10 psi (0.7 Bar)
- Hazardous Locations:** Rated for sensor and cable installation in Class I, Div. I,II, Groups C,D,E,F,G
Hazardous locations with optional Intrinsic Safety Barriers

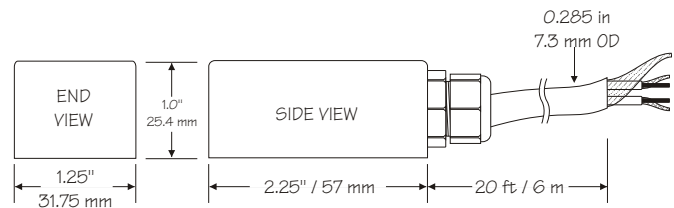

SE3 DOPPLER SENSOR

APPENDIX B - CONVERSION TABLE

CONVERSION GUIDE		
FROM	TO	MULTIPLY BY
US GALLONS	CUBIC FEET	0.1337
US GALLONS	IMPERIAL GALS	0.8327
US GALLONS	LITRES	3.785
US GALLONS	CUBIC METERS	0.003785
LITRES/SEC	GPM	15.85
LITRES	CUBIC METERS	0.001
BARRELS	US GALLONS	42
BARRELS	IMPERIAL GALS	34.9726
BARRELS	LITRES	158.9886
INCHES	MM	25.4
DEGREES F	DEGREES C	(F-32) x 0.556
POUNDS	KILOGRAMS	0.453
PSI	BAR	0.0676
FOOT ²	METER ²	0.0929

Note: BARRELS are U.S. oil barrels.

PIPE CHARTS

Carbon Steel & PVC Pipe

Pipe Size	Pipe O.D.	Standard		Extra Heavy		Dbl. Extra Heavy		Schedule 10		Schedule 20		Schedule 30		Schedule 40	
		I.D.	WALL	I.D.	WALL	I.D.	WALL	I.D.	WALL	I.D.	WALL	I.D.	WALL	I.D.	WALL
½	.840	.622	.109	.546	.147	.252	.294							.622	.109
¼	1.050	.824	.113	.742	.154	.434	.308							.824	.113
1	1.315	1.049	.133	.957	.179	.599	.358							1.049	.133
1¼	1.660	1.380	.140	1.278	.191	.896	.382							1.380	.140
1½	1.900	1.610	.145	1.500	.200	1.100	.400							1.610	.145
2	2.375	2.067	.154	1.939	.218	1.503	.436							2.067	.154
2½	2.875	2.469	.203	2.323	.276	1.771	.552							2.469	.203
3	3.500	3.068	.216	2.900	.300	2.300	.600							3.068	.216
3½	4.000	3.548	.226	3.364	.318	2.728	.636							3.548	.226
4	4.500	4.026	.237	3.826	.337	3.152	.674							4.026	.237
5	5.563	5.047	.258	4.813	.375	4.063	.750							5.047	.258
6	6.625	6.065	.280	5.761	.432	4.897	.864							6.065	.280
8	8.625	7.981	.322	7.625	.500	6.875	.875			8.125	.250	8.071	.277	7.981	.322
10	10.750	10.020	.365	9.750	.500	8.750	1.000			10.250	.250	10.136	.307	10.020	.365
12	12.750	12.000	.375	11.750	.500	10.750	1.000			12.250	.250	12.090	.330	11.938	.406
14	14.000	13.250	.375	13.000	.500			13.500	.250	13.376	.312	13.250	.375	13.124	.438
16	16.000	15.250	.375	15.000	.500			15.500	.250	15.376	.312	15.250	.375	15.000	.500
18	18.000	17.250	.375	17.000	.500			17.500	.250	17.376	.312	17.124	.438	16.876	.562
20	20.000	19.250	.375	19.000	.500			19.500	.250	19.250	.375	19.000	.500	18.814	.593
22	22.000	21.250	.375	21.000	.500			21.500	.250	21.250	.375	21.000	.500		
24	24.000	23.250	.375	23.000	.500			23.500	.250	23.250	.375	22.876	.562	22.626	.687
26	26.000	25.250	.375	25.000	.500			25.376	.312	25.000	.500				
28	28.000	27.250	.375	27.000	.500			27.376	.312	27.000	.500	26.750	.625		
30	30.000	29.250	.375	29.000	.500			29.376	.312	29.000	.500	28.750	.625		
32	32.000	31.250	.375	31.000	.500			31.376	.312	31.000	.500	30.750	.625		
34	34.000	33.250	.375	33.000	.500			33.376	.312	33.000	.500	32.750	.625		
36	36.000	35.250	.375	35.000	.500			35.376	.312	35.000	.500	34.750	.625		
42	42.000	41.250	.375	41.000	.500					41.000	.500	40.750	.625		

Ductile Iron Pipe - Standard Classes

Size INCH	OUTSIDE DIA. INCH	Class 50		Class 51		Class 52		Class 53		Class 54		Class 55		Class 56		CEMENT LINING	
		WALL	I.D.	WALL	I.D.	WALL	I.D.	WALL	I.D.	WALL	I.D.	WALL	I.D.	WALL	I.D.	**STD THICKNESS	**DOUBLE THICKNESS
3	3.96			0.25	3.46	0.28	3.40	0.31	3.34	0.34	3.28	0.37	3.22	0.41	3.14		
4	4.80			0.26	4.28	0.29	4.22	0.32	4.16	0.35	4.10	0.38	4.04	0.44	3.93		
6	6.90	0.25	6.40	0.28	6.34	0.31	6.28	0.34	6.22	0.37	6.16	0.40	6.10	0.43	6.04	.125	.250
8	9.05	0.27	8.51	0.30	8.45	0.33	8.39	0.36	8.33	0.39	8.27	0.42	8.21	0.45	8.15		
10	11.10	0.39	10.32	0.32	10.46	0.35	10.40	0.38	10.34	0.41	10.28	0.44	10.22	0.47	10.16		
12	13.20	0.31	12.58	0.34	12.52	0.37	12.46	0.40	12.40	0.43	12.34	0.46	12.28	0.49	12.22		
14	15.30	0.33	14.64	0.36	14.58	0.39	14.52	0.42	14.46	0.45	14.40	0.48	14.34	0.51	14.28		
16	17.40	0.34	16.72	0.37	16.66	0.40	16.60	0.43	16.54	0.46	16.48	0.49	16.42	0.52	16.36	.1875	.375
18	19.50	0.35	18.80	0.38	18.74	0.41	18.68	0.44	18.62	0.47	18.56	0.50	18.50	0.53	18.44		
20	21.60	0.36	20.88	0.39	20.82	0.42	20.76	0.45	20.70	0.48	20.64	0.51	20.58	0.54	20.52		
24	25.80	0.38	25.04	0.41	24.98	0.44	24.92	0.47	24.86	0.50	24.80	0.53	24.74	0.56	24.68		
30	32.00	0.39	31.22	0.43	31.14	0.47	31.06	0.51	30.98	0.55	30.90	0.59	30.82	0.63	30.74	.250	.500
36	38.30	0.43	37.44	0.48	37.34	0.62	37.06	0.58	37.14	0.63	37.04	0.68	36.94	0.73	36.84		
42	44.50	0.47	43.56	0.53	43.44	0.59	43.32	0.65	43.20	0.71	43.08	0.77	42.96	0.83	42.84		
48	50.80	0.51	49.78	0.58	49.64	0.65	49.50	0.72	49.36	0.79	49.22	0.86	49.08	0.93	48.94		
54	57.10	0.57	55.96	0.65	55.80	0.73	55.64	0.81	55.48	0.89	55.32	0.97	55.16	1.05	55.00		

**REDUCE I.D. BY DIMENSION SHOWN

Stainless Steel, Hastelloy "C" & Titanium Pipe

Pipe Size	Pipe O.D.	Schedule 5 S (a)		Schedule 10 S (a)		Schedule 40 S		Schedule 80 S	
		I.D.	WALL	I.D.	WALL	I.D.	WALL	I.D.	WALL
1/2	.840	.710	.065	.674	.083	.622	.109	.546	.147
1/4	1.050	.920	.065	.884	.083	.824	.113	.742	.154
1	1.315	1.185	.065	1.097	.109	1.049	.133	.957	.179
1 1/4	1.660	1.530	.065	1.442	.109	1.380	.140	1.278	.191
1 1/2	1.900	1.770	.065	1.682	.109	1.610	.145	1.500	.200
2	2.375	2.245	.065	2.157	.109	2.067	.154	1.939	.218
2 1/2	2.875	2.709	.083	2.635	.120	2.469	.203	2.323	.276
3	3.500	3.334	.083	3.260	.120	3.068	.216	2.900	.300
3 1/2	4.000	3.834	.083	3.760	.120	3.548	.226	3.364	.318
4	4.500	4.334	.083	4.260	.120	4.026	.237	3.826	.337
5	5.563	5.345	.109	5.295	.134	5.047	.258	4.813	.375
6	6.625	6.407	.109	6.357	.134	6.065	.280	5.761	.432
8	8.625	8.407	.109	8.329	.148	7.981	.322	7.625	.500
10	10.750	10.482	.134	10.420	.165	10.020	.365	9.750	.500
12	12.750	12.438	.156	12.390	.180	12.000	.375	11.750	.500
14	14.000	13.688	.156	13.624	.188				
16	16.000	15.670	.165	15.624	.188				
18	18.000	17.670	.165	17.624	.188				
20	20.000	19.634	.188	19.564	.218				
22	22.000	21.624	.188	21.564	.218				
24	24.000	23.563	.218	23.500	.250				

Pipe Size	Pipe O.D.	Schedule 60		Schedule 80		Schedule 100		Schedule 120		Schedule 140		Schedule 160	
		I.D.	WALL	I.D.	WALL	I.D.	WALL	I.D.	WALL	I.D.	WALL	I.D.	WALL
1/2	.840			.546	.147							.466	.187
1/4	1.050			.742	.154							.614	.218
1	1.315			.957	.179							.815	.250
1 1/4	1.660			1.278	.191							1.160	.250
1 1/2	1.900			1.500	.200							1.338	.281
2	2.375			1.939	.218							1.689	.343
2 1/2	2.875			2.323	.276							2.125	.375
3	3.500			2.900	.300							2.624	.438
3 1/2	4.000			3.364	.318								
4	4.500			3.826	.337			3.624	.438			3.438	.531
5	5.563			4.813	.375			4.563	.500			4.313	.625
6	6.625			5.761	.432			5.501	.562			5.189	.718
8	8.625	7.813	.406	7.625	.500	7.439	.593	7.189	.718	7.001	.812	6.813	.906
10	10.750	9.750	.500	9.564	.593	9.314	.718	9.064	.843	8.750	1.000	8.500	1.125
12	12.750	11.626	.562	11.376	.687	11.064	.843	10.750	1.000	10.500	1.125	10.126	1.312
14	14.000	12.814	.593	12.500	.750	12.126	.937	11.814	1.093	11.500	1.250	11.188	1.406
16	16.000	14.688	.656	14.314	.843	13.938	1.031	13.564	1.218	13.124	1.438	12.814	1.593
18	18.000	16.500	.750	16.126	.937	15.688	1.156	15.250	1.375	14.876	1.562	14.438	1.781
20	20.000	18.376	.812	17.938	1.031	17.438	1.281	17.000	1.500	16.500	1.750	16.064	1.968
22	22.000	20.250	.875	19.750	1.125	19.250	1.375	18.750	1.625	18.250	1.875	17.750	2.125
24	24.000	22.064	.968	21.564	1.218	20.938	1.531	20.376	1.812	19.876	2.062	19.314	2.343

Cast Iron Pipe - ASA Standard

Pipe Size	Pipe O.D.	Class 50		Class 100		Class 150		Class 200		Class 250		Class 300		Class 350	
		WALL	I.D.	WALL	I.D.	WALL	I.D.	WALL	I.D.	WALL	I.D.	WALL	I.D.	WALL	I.D.
3	3.96	0.32	3.32	0.32	3.32	0.32	3.32	0.32	3.32	0.32	3.32	0.32	3.32	0.32	3.32
4	4.80	0.35	4.10	0.35	4.10	0.35	4.10	0.35	4.10	0.35	4.10	0.35	4.10	0.35	4.10
6	6.90	0.38	6.14	0.38	6.14	0.38	6.14	0.38	6.14	0.38	6.14	0.38	6.14	0.38	6.14
8	9.05	0.41	8.23	0.41	8.23	0.41	8.23	0.41	8.23	0.41	8.23	0.41	8.23	0.41	8.23
10	11.10	0.44	10.22	0.44	10.22	0.44	10.22	0.44	10.22	0.44	10.22	0.48	10.14	0.52	10.06
12	13.20	0.48	12.24	0.48	12.24	0.48	12.24	0.48	12.24	0.52	12.16	0.52	12.16	0.56	12.08
14	15.30	0.48	14.34	0.51	14.28	0.51	14.28	0.55	14.20	0.59	14.12	0.59	14.12	0.64	14.02
16	17.40	0.54	16.32	0.54	16.32	0.54	16.32	0.58	16.24	0.63	16.14	0.68	16.04	0.68	16.04
18	19.50	0.54	18.42	0.58	18.34	0.58	18.34	0.63	18.24	0.68	18.14	0.73	18.04	0.79	17.92
20	21.60	0.57	20.46	0.62	20.36	0.62	20.36	0.67	20.26	0.72	20.16	0.78	20.04	0.84	19.92
24	25.80	0.63	24.54	0.68	24.44	0.73	24.34	0.79	24.22	0.79	24.22	0.85	24.10	0.92	23.96

Cast Iron Pipe - AWWA Standard

Pipe Size	Class A 100 Ft. 43 PSIG			Class B 200 Ft. 86 PSIG			Class C 300 Ft. 130 PSIG			Class D 400 Ft. 173 PSIG		
	O.D.	WALL	I.D.	O.D.	WALL	I.D.	O.D.	WALL	I.D.	O.D.	WALL	I.D.
3	3.80	0.39	3.02	3.96	0.42	3.12	3.96	0.45	3.06	3.96	0.48	3.00
4	4.80	0.42	3.96	5.00	0.45	4.10	5.00	0.48	4.04	5.00	0.52	3.96
6	6.90	0.44	6.02	7.10	0.48	6.14	7.10	0.51	6.08	7.10	0.55	6.00
8	9.05	0.46	8.13	9.05	0.51	8.03	9.30	0.56	8.18	9.30	0.60	8.10
10	11.10	0.50	10.10	11.10	0.57	9.96	11.40	0.62	10.16	11.40	0.68	10.04
12	13.20	0.54	12.12	13.20	0.62	11.96	13.50	0.68	12.14	13.50	0.75	12.00
14	15.30	0.57	14.16	15.30	0.66	13.98	15.65	0.74	14.17	15.65	0.82	14.01
16	17.40	0.60	16.20	17.40	0.70	16.00	17.80	0.80	16.20	17.80	0.89	16.02
18	19.50	0.64	18.22	19.50	0.75	18.00	19.92	0.87	18.18	19.92	0.96	18.00
20	21.60	0.67	20.26	21.60	0.80	20.00	22.06	0.92	20.22	22.06	1.03	20.00
24	25.80	0.76	24.28	25.80	0.89	24.02	26.32	1.04	24.22	26.32	1.16	24.00
30	31.74	0.88	29.98	32.00	1.03	29.94	32.40	1.20	30.00	32.74	1.37	30.00
36	37.96	0.99	35.98	38.30	1.15	36.00	38.70	1.36	39.98	39.16	1.58	36.00
42	44.20	1.10	42.00	44.50	1.28	41.94	45.10	1.54	42.02	45.58	1.78	42.02
48	50.50	1.26	47.98	50.80	1.42	47.96	51.40	1.71	47.98	51.98	1.96	48.06
54	56.66	1.35	53.96	57.10	1.55	54.00	57.80	1.90	54.00	58.40	2.23	53.94
60	62.80	1.39	60.02	63.40	1.67	60.06	64.20	2.00	60.20	64.82	2.38	60.06
72	75.34	1.62	72.10	76.00	1.95	72.10	76.88	2.39	72.10			
84	87.54	1.72	84.10	88.54	2.22	84.10						

Pipe Size	Class E 500 Ft. 217 PSIG			Class F 600 Ft. 260 PSIG			Class G 700 Ft. 304 PSIG			Class H 800 Ft. 347 PSIG		
	O.D.	WALL	I.D.	O.D.	WALL	I.D.	O.D.	WALL	I.D.	O.D.	WALL	I.D.
6	7.22	0.58	6.06	7.22	0.61	6.00	7.38	0.65	6.08	7.38	0.69	6.00
8	9.42	0.66	8.10	9.42	0.71	8.00	9.60	0.75	8.10	9.60	0.80	8.00
10	11.60	0.74	10.12	11.60	0.80	10.00	11.84	0.86	10.12	11.84	0.92	10.00
12	13.78	0.82	12.14	13.78	0.89	12.00	14.08	0.97	12.14	14.08	1.04	12.00
14	15.98	0.90	14.18	15.98	0.99	14.00	16.32	1.07	14.18	16.32	1.16	14.00
16	18.16	0.98	16.20	18.16	1.08	16.00	18.54	1.18	16.18	18.54	1.27	16.00
18	20.34	1.07	18.20	20.34	1.17	18.00	20.78	1.28	18.22	20.78	1.39	18.00
20	22.54	1.15	20.24	22.54	1.27	20.00	23.02	1.39	20.24	23.02	1.51	20.00
24	26.90	1.31	24.28	26.90	1.45	24.00	27.76	1.75	24.26	27.76	1.88	24.00
30	33.10	1.55	30.00	33.46	1.73	30.00						
36	39.60	1.80	36.00	40.04	2.02	36.00						

